

Series AG



CHARACTERISTICS

Applications:

- Light oil.
- One pipe or two pipe systems.
- Self-priming.
- Hub \varnothing 32 mm or hub \varnothing 54 mm with flange.
- Capacity from 50 l/h to 280 l/h.

FUNCTION

The suction vacuum generated by the gears sucks up the fuel through the suction connection; it crosses the filter and the fuel is sent under pressure to the pressure adjustment screw.

The hydraulic valve opens when oil pressure gets over spring strength settled by pressure adjustment screw and the oil reaches nozzle line.

In two pipe systems the exceeding oil flows into the tank through the return line; in one pipe system, after the removing the by-pass screw, it goes back to the gears.

When burner stops, the oil pressure immediately comes down and the spring strength moves the piston which stop the fluid flow to the line and at the same time allows the forwarding of the light oil to the return line.

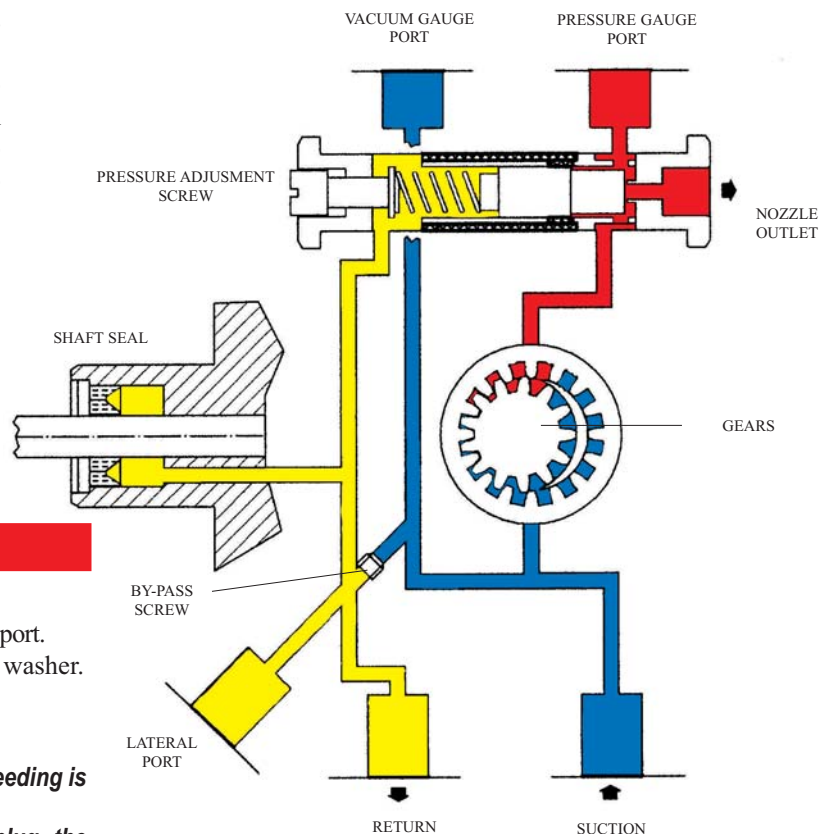

CONVERSION 2 PIPES - 1 PIPE SYSTEM

For the conversion proceed as follow:

- Remove the by-pass screw, located inside the lateral port.
- Lock the return port with a steel plug G 1/4 and washer.

ATTENTION:

In two-pipe system oil pump is self-priming, the bleeding is obtained through the return line.

In one-pipe system the return line is closed by plug, the bleeding must be obtained through the nozzle or opening the pressure gauge port, to accelerate the way out of the air.

TECHNICAL DATA

HYDRAULIC DATA

Factory settings	12 bar
Pressure range	4 - 25 bar
Viscosity range	2,8 - 75 cSt
Oil temperature	70°C max
Inlet pressure	2 bar max
Recycle pressure	2 bar max
Suction vacuum	0,45 bar max
Speed	2800 - 3480 rpm
Starting torque	0,30 Nm
Capacity	see graphs
Power consumption	see graphs

GENERAL DATA

Mounting	Hub \varnothing 32 mm or Flange \varnothing 54 mm according to EN 225	
Connections	Nozzle outlet	G 1/8
	Pressure gauge port	G 1/8
	Vacuum gauge port	G 1/8
	Suction	G 1/4
	Return	G 1/4
Strainer	Open area	142 cm ²
	Mesh	100 μ m
Weight	2,0 kg	

PRESSURE - CAPACITY DIAGRAM

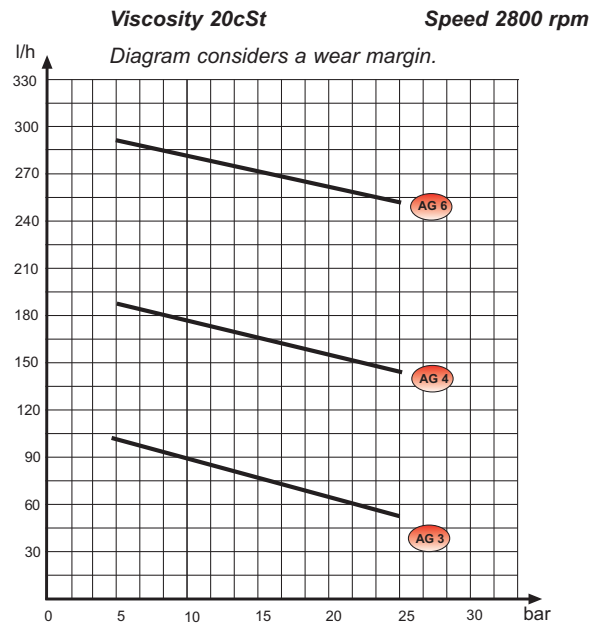

POWER CONSUMPTION - PRESSURE DIAGRAM

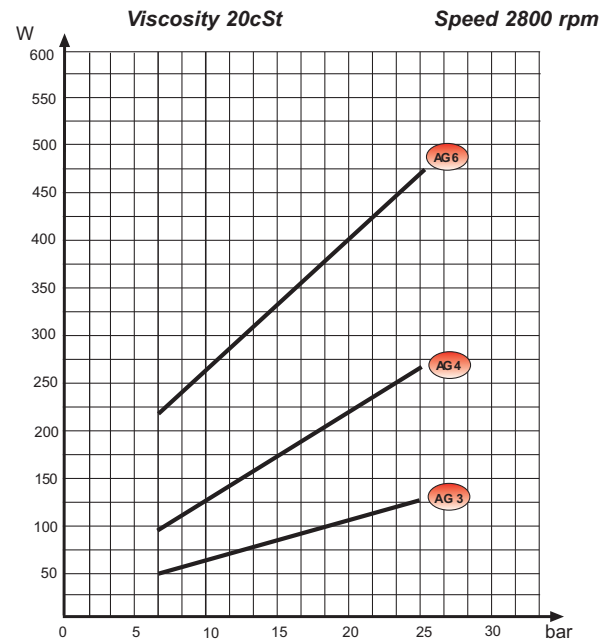

IDENTIFICATION OF THE PUMP

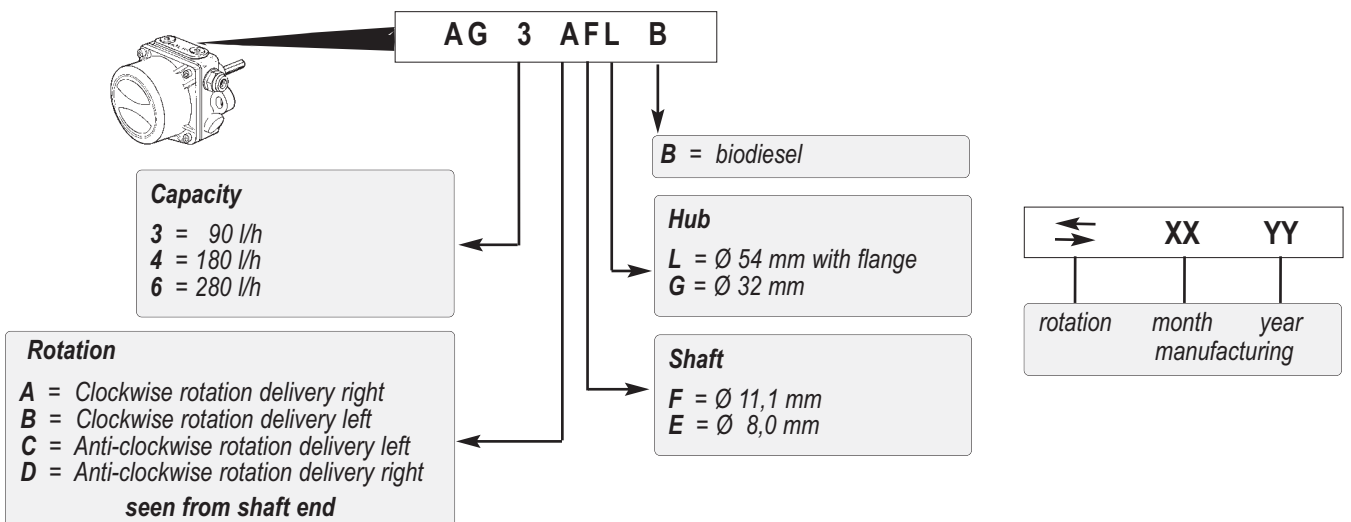

COMPONENTS OF THE PUMP

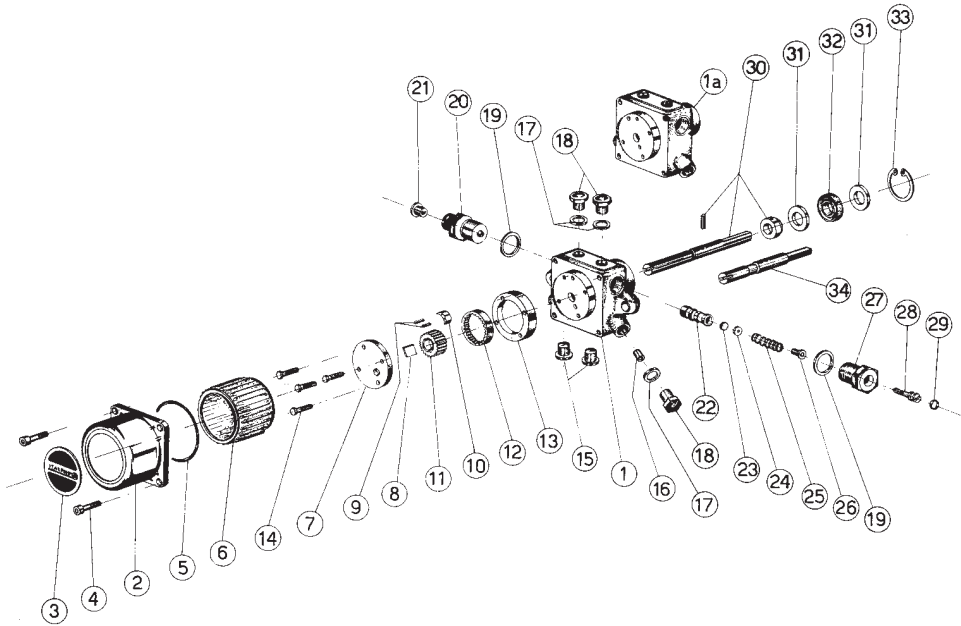

INSTALLATION OF THE PUMP

- The pump can be installed in all indicated positions.
- Make sure that the characteristics of the pump are compatible with those of the motor or of the boiler.
- Control the rotation of pump-motor.

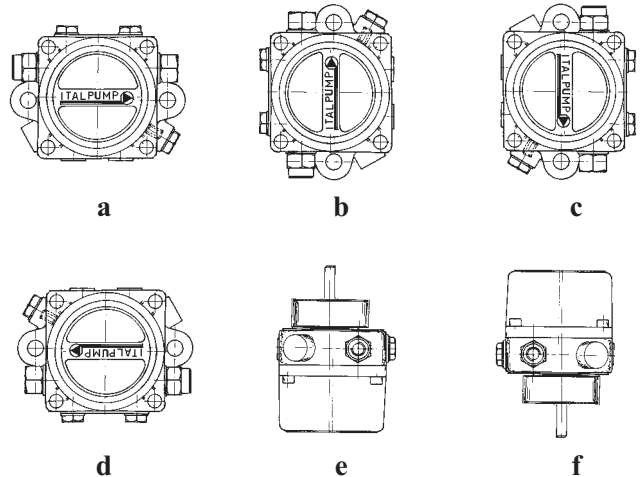

In the hub mounting version the coupling pump-motor must be realized using 3 head screws without; otherwise you can have significant reductions of pump life.

REGULATION OF THE PUMP PRESSURE

- Apply the manometer on the pressure gauge port.
- Rotate with the slotted screwdriver changing the pressure which has to be:
 - Pressure max: 25 bar
 - Pressure min: 4 bar

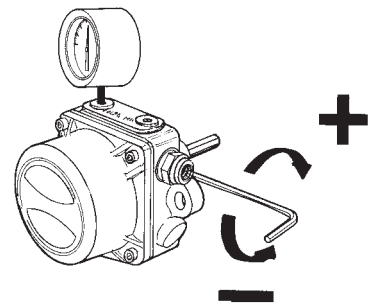

CLEANING OF THE FILTER

- Remove the cover as indicated in the figure.
- Extract the filter and clean it with the clean oil fuel.

ATTENTION: This operations have to be made periodically by the technical personnel.

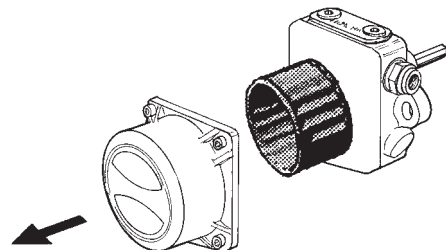

The repairs which require the substitution of pieces, must be realized by the manufacturer.

VERSIONS OF THE PUMP

Flange mounting connection \varnothing 54 mm

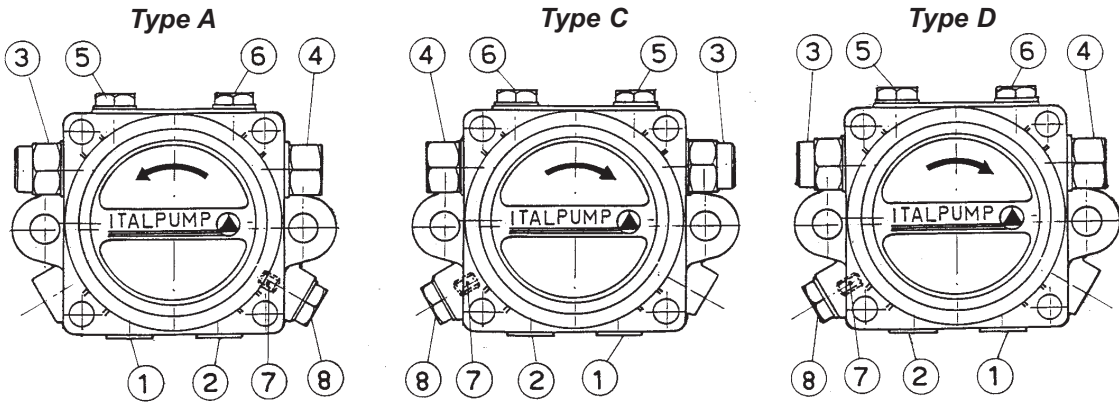

Hub mounting connection \varnothing 32 mm

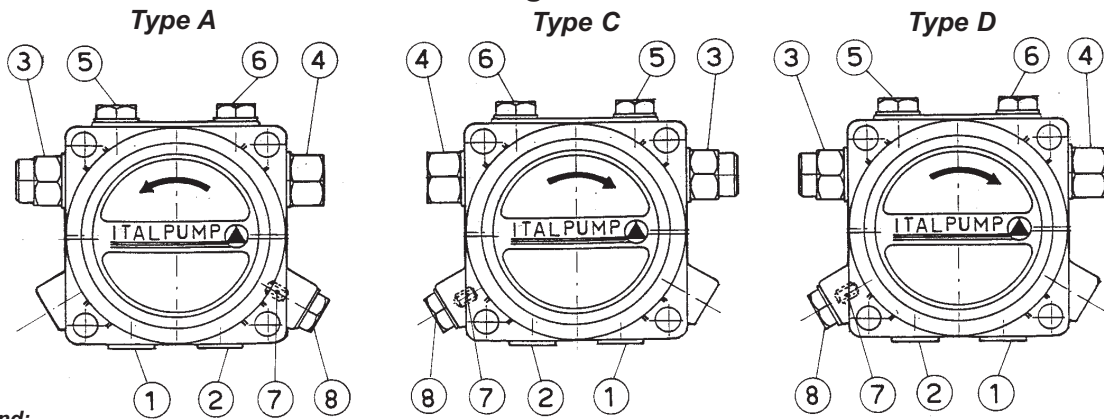

Legend:

1 - Suction
2 - Return

3 - Nozzle outlet
4 - Pressure adjustment screw

5 - Pressure gauge port
6 - Vacuum gauge port

7 - By-pass screw
8 - Lateral port

DIMENSIONS OF THE PUMP

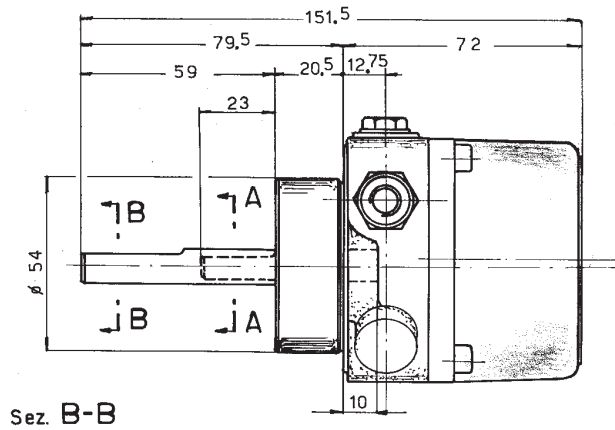
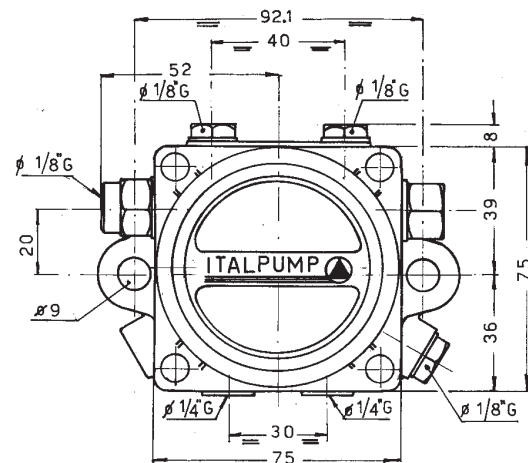

Pump type A,
hub \varnothing 54 mm with flange

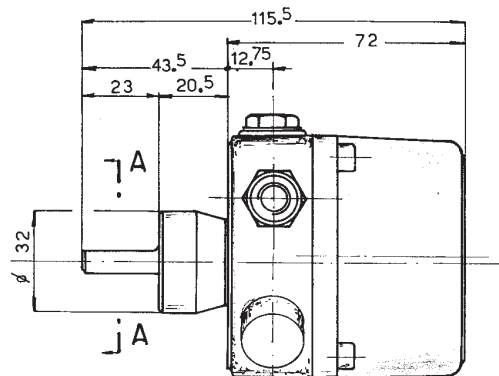
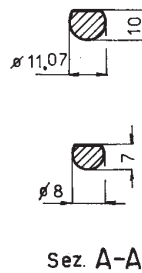
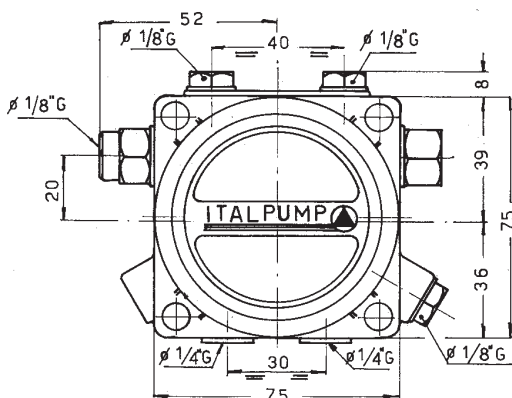

Pump type A,
hub \varnothing 32 mm